



Spherical moulded type expansion joints / flexible connectors with zinc electroplated floating steel flanges for easy alignment long radius arch bellow design permits substantial movements in all planes.

## Application

Installation of REJFF is recommended as expansion joints within the piping system and at connection points of piping suction discharge.

- Compensate for axial transverse and angular pipe movements thereby protecting the system from stresses and damage due to thermal expansion and contraction of piping, minor pipe misalignment and hydraulic surge effects.
- Eliminate need for pipe expansion loops that are expensive and require considerable space.
- Significantly reduce noise and vibration transmitted in the system through pipe walls.
- Allow vibration isolators to function properly, by providing flexibility at equipment connection.
- Cushion water hammer by expanding volumetrically, thus protecting against sudden startup / surge forces or shocks.

## Typical examples of usage include

- At inlet and outlet of HVAC equipment - Pumps, AHUs, Chillers, Cooling Tower, Condensers.
- In HVAC chilled / hot water piping - risers, circulation lines, across building expansion joints.
- Process Piping, Power Plants, Water Distribution etc.

## Features

- The bellows are moulded under high pressure and impregnated with multi ply nylon tire cord and spring-steel wire reinforcement. This makes them suitable for both positive pressure and vacuum applications.
- Long radius arch bellow design provides excellent axial, transverse and angular deflection capability.
- Spherical shape of bellow ensures smooth flow of fluid, resulting in negligible pressure drop across the joint.
- Substantial steel-reinforced moulded beads at each end of bellow eliminate the need for gaskets.
- Captive floating flanges facilitate alignment with pipe during installation. These are grooved in order to accommodate the bellow end-beads.
- The floating flanges are epoxy powder coated for corrosion resistance.
- Each unit is individually tested at 150% of rated maximum working pressure before leaving works.

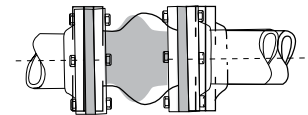

AXIAL extension

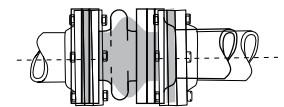

AXIAL compression

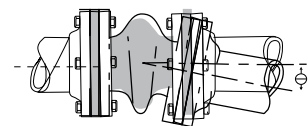

ANGULAR bending of the centerline

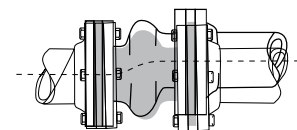

LATERAL shear or perpendicular to centerline

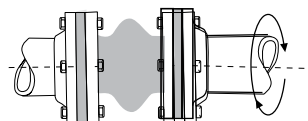

TORSIONAL rotation about the centerline, twist

- Due to policy of continual improvement, the specifications are subject to change without prior notice.
- Measurements are subject to 5% tolerance.
- To achieve good results do not over load fitting more than designed parameters as per drawing / catalogue.
- Compliance - As per FSA Standards USA.

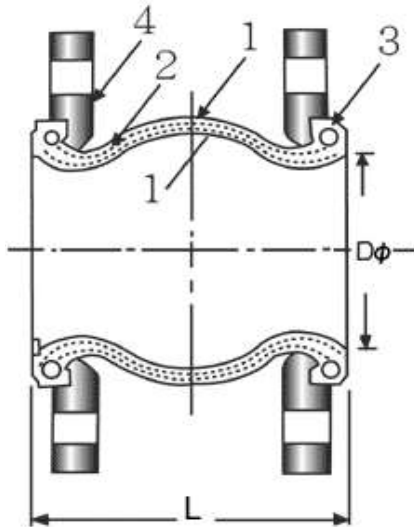

### Standard Structure

Item No.	Part	Material
1	Body	CR (Neoprene)/EPDM or NBR
2	Reinforce	Nylon Cord Fabric
3	Wire	Hard Steel Wire
4	Floating Flange	Mild Steel Zinc Plated as per ASTM A36

\* Other Polymers available on Request.

### Temperature/Pressure Ratings

Maximum temperature	115°C (EPDM/Neoprene or NBR)
Vacuum rating	full vacuum (26"Hg)
Working pressure depends on temperature and at higher temperature, the pressure ratings are reduced slightly	

### PN - 10

Nominal Size (I.D.)	Length Nominal f.f. Inches	Flange Dia Nominal Inches	Axial Compression Inches	Movements Elongation Inches	Lateral Inches	Angular Degrees	Expansion Joint Style	BS 10 Table D			Operating Conditions		
								Hole No. of Inches	No. of Holes	B.C.D. (Approx) Inches	Pressure Design	Test Pressure	
1	25	5.91	4.49	0.51	0.47	0.51	15°	REJFF	0.59	4	3.27	10 Bar	15 Bar
1.25	32	5.91	4.76	0.51	0.47	0.51	15°	REJFF	0.59	4	3.43	10 Bar	15 Bar
1.5	40	5.91	5.24	0.51	0.47	0.51	15°	REJFF	0.59	4	3.86	10 Bar	15 Bar
2	50	5.91	5.98	0.51	0.47	0.51	15°	REJFF	0.71	4	4.49	10 Bar	15 Bar
2.5	65	5.91	6.50	0.51	0.47	0.51	15°	REJFF	0.71	4	5.00	10 Bar	15 Bar
3	80	5.91	7.24	0.51	0.47	0.51	15°	REJFF	0.71	4	5.75	10 Bar	15 Bar
4	100	5.91	8.46	0.63	0.47	0.63	15°	REJFF	0.71	4	7.01	10 Bar	15 Bar
5	125	5.91	10.00	0.63	0.47	0.63	15°	REJFF	0.71	8	8.27	10 Bar	15 Bar
6	150	5.91	10.98	0.63	0.47	0.63	15°	REJFF	0.71	8	9.25	10 Bar	15 Bar
8	200	5.91	13.27	0.63	0.47	0.63	15°	REJFF	0.71	8	11.50	10 Bar	15 Bar
10	250	7.87	15.98	0.63	0.59	0.63	15°	REJFF	0.87	8	14.02	10 Bar	15 Bar
12	300	7.87	17.99	0.63	0.59	0.63	15°	REJFF	0.87	12	15.98	10 Bar	15 Bar
14	350	7.87	20.75	0.63	0.59	0.63	15°	REJFF	0.98	12	18.50	10 Bar	15 Bar

### Other Available

- **Pressure Rating** - REJFF rated for higher pressures can be supplied. Specify required rating.
- **Bellow Material** - Neoprene/EPDM (standard), (for temperature rating up to 115°C), NBR, Chlorobutyl Hypalon available on request.
- **Flange Drilling** - BS 10 Table-D/ANSI 125/150# (standard); any other standard such ANSI, JIS (specify by name).

**Compliance** - ASTM F 1123-87 (2004). Testing & Tolerances as per Fluid Sealing Association Standard USA.

**Other Flange Drilling Available** : BS 10 Table D/E/F, ANSI B16.5 Class 125/150, BS 4504/DIN 2501/BS 4504 PN 16 or as per customer requirement.



## PN - 16

Nominal Size (I.D.)	Length Nominal f.f. Inches	Flange Dia Nominal Inches	Axial Compression Inches	Movements			Angular Degrees	Expansion Joint Style	ANSI 125/150# LBS			Operating Conditions	
				Elongation Inches	Lateral Inches				Hole Dia Inches	No. of Holes NOS.	B.C.D. (Approx) Inches	Pressure Design	Test Pressure
1	25	5.91	4.25	0.51	0.47	0.51	15°	REJFF	0.59	4	3.11	16 Bar	24 Bar
1.25	32	5.91	4.65	0.51	0.47	0.51	15°	REJFF	0.51	4	3.50	16 Bar	24 Bar
1.5	40	5.91	5.00	0.51	0.47	0.51	15°	REJFF	0.59	4	3.86	16 Bar	24 Bar
2	50	5.91	5.98	0.51	0.47	0.51	15°	REJFF	0.75	4	4.76	16 Bar	24 Bar
2.5	65	5.91	7.01	0.51	0.47	0.51	15°	REJFF	0.75	4	5.51	16 Bar	24 Bar
3	80	5.91	7.52	0.51	0.47	0.51	15°	REJFF	0.75	4	5.98	16 Bar	24 Bar
4	100	5.91	9.02	0.63	0.47	0.63	15°	REJFF	0.75	8	7.52	16 Bar	24 Bar
5	125	5.91	10.00	0.63	0.47	0.63	15°	REJFF	0.91	8	8.50	16 Bar	24 Bar
6	150	5.91	10.98	0.63	0.47	0.63	15°	REJFF	0.91	8	9.49	16 Bar	24 Bar
8	200	5.91	13.50	0.63	0.47	0.63	15°	REJFF	0.91	8	11.73	16 Bar	24 Bar
10	250	7.87	15.98	0.63	0.59	0.63	15°	REJFF	0.98	12	14.25	16 Bar	24 Bar
12	300	7.87	19.02	0.63	0.59	0.63	15°	REJFF	0.98	12	17.01	16 Bar	24 Bar
14	350	7.87	20.98	0.63	0.59	0.63	15°	REJFF	1.10	12	18.74	16 Bar	24 Bar

## PN - 20

Nominal Size (I.D.)	Length Nominal f.f. Inches	Flange Dia Nominal Inches	Axial Compression Inches	Movements			Angular Degrees	Expansion Joint Style	ANSI 125/150# LBS			Operating Conditions	
				Elongation Inches	Lateral Inches				Hole Dia Inches	No. of Holes NOS.	B.C.D. (Approx) Inches	Pressure Design	Test Pressure
1	25	5.91	4.25	0.51	0.47	0.51	15°	REJFF	0.59	4	3.11	20 Bar	30 Bar
1.25	32	5.91	4.65	0.51	0.47	0.51	15°	REJFF	0.51	4	3.50	20 Bar	30 Bar
1.5	40	5.91	5.00	0.51	0.47	0.51	15°	REJFF	0.59	4	3.86	20 Bar	30 Bar
2	50	5.91	5.98	0.51	0.47	0.51	15°	REJFF	0.75	4	4.76	20 Bar	30 Bar
2.5	65	5.91	7.01	0.51	0.47	0.51	15°	REJFF	0.75	4	5.51	20 Bar	30 Bar
3	80	5.91	7.52	0.51	0.47	0.51	15°	REJFF	0.75	4	5.98	20 Bar	30 Bar
4	100	5.91	9.02	0.63	0.47	0.63	15°	REJFF	0.75	8	7.52	20 Bar	30 Bar
5	125	5.91	10.00	0.63	0.47	0.63	15°	REJFF	0.91	8	8.50	20 Bar	30 Bar
6	150	5.91	10.98	0.63	0.47	0.63	15°	REJFF	0.91	8	9.49	20 Bar	30 Bar
8	200	5.91	13.50	0.63	0.47	0.63	15°	REJFF	0.91	8	11.73	20 Bar	30 Bar
10	250	7.87	15.98	0.63	0.59	0.63	15°	REJFF	0.98	12	14.25	20 Bar	30 Bar
12	300	7.87	19.02	0.63	0.59	0.63	15°	REJFF	0.98	12	17.01	20 Bar	30 Bar
14	350	7.87	20.98	0.63	0.59	0.63	15°	REJFF	1.10	12	18.74	20 Bar	30 Bar

## Temperature/Pressure Ratings

Maximum temperature	115°C (EPDM/Neoprene or NBR)
Vacuum rating	full vacuum (26"Hg)
Working pressure depends on temperature and at higher temperature, the pressure ratings are reduced slightly	

\* Other Polymers available on Request.

- **Bellow Material** - Neoprene/EPDM (standard), (for temperature rating up to 115°C), NBR, Chlorobutyl Hypalon available on request.

**Compliance** - ASTM F 1123-87 (2004). Testing & Tolerances as per Fluid Sealing Association Standard USA.



## Why Control Units are Required

- Lack of Proper pipe anchors - Initial surge of pump at an elbow may cause hyper-extension.
- Lack of proper pipe supports - Easyflex expansion joints and vibration dampeners are not designed to support the weight of the piping system.
- Lack of proper alignment guides - Control rods will prevent lateral movement beyond design specifications.
- Wide fluctuations of temperature - The changing from hot to cold media may cause excessive expansion or contraction even when the pipe is properly anchored.
- Testing at elevated pressures - The use of anchors and/or control rods is required to offset the thrust.

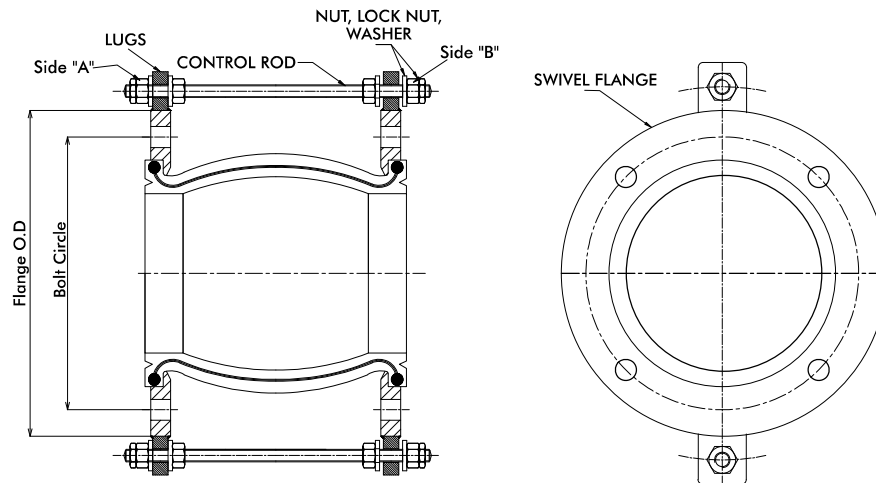

## Pre-Installation Check List

- Compare the requirements of the system to ensure the proper number of control rods have been specified. (Minimum of two (2) required.)
- Check Control Units to be sure all parts are included. The unit consists of minimum four (4) lugs, two (2) control rods with six (6) nuts and six (6) metal / rubber washers. For bigger sizes and higher pressures the quantities might increase. Contact our Engg. Dept. or refer drawing.

## Installation

- Bolt the control unit plates to the outer side of the end flanges at the same time while the bolt is being installed through the end flange and the control unit / lugs. They are to be equally spaced around the circumference of the flange.
- Install the control rod through the top hole in each lugs after placing rubber/metal washer on either side of the lugs. (See illustration above.)
- Tighten the first two nuts ("A" location) in the direction of flow tightly. Check the recommended movement for the particular size from our catalogue and keep the second set of nuts ("B" location) loose accordingly. The second check nut should be tightened keeping space/gap for movement capability.

### Note :

If excessive compression exists, optional compression sleeves should be specified. The compression sleeves will limit the compression to the maximum allowable movement.

- Due to policy of continual improvement, the specifications are subject to change without prior notice.
- Measurements are subject to 5% tolerance.
- To achieve good results do not over load fitting more than designed parameters as per drawing / catalogue.
- Compliance - As per FSA Standards USA.