

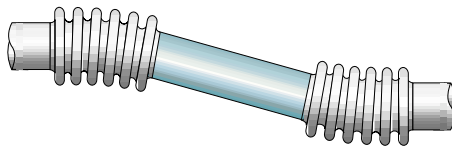

Style EFUEJ Universal Expansion Joints consist of two bellows separated by a pipe spool. This configuration accommodates large lateral movements, in addition to axial compression and extension and angular deflection. These expansion joints have no restraints to resist pressure thrust and like the singles, the piping designer must provide separate anchoring to handle pressure thrust.

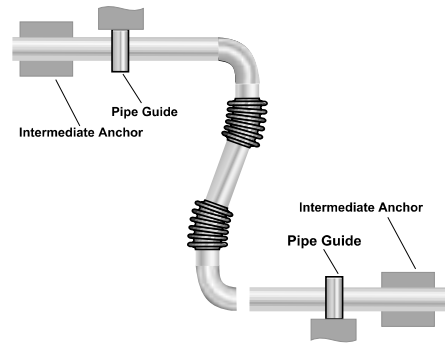

UNIVERSAL (EFUEJ)



Style EFUTEJ Universal Tied, Expansion Joints contain two bellows separated by a pipe spool and tie rods designed to contain the pressure thrust force. These expansion joints are generally designed to accommodate lateral movement only. A universal expansion joint can be designed to have a very low lateral spring force to minimize forces on adjacent equipment. A two tie rod design can also accept angular deflection in a single plane.

The tie rods are usually at or near ambient temperatures and, therefore, do not expand and contract as a function of the temperature of the media within the pipe. As a result, the thermal expansion of the length of pipe between the tie rod end plates is forced into the bellows as an axial movement. The bellows design must accommodate this axial thermal expansion as well as the specified lateral movement.

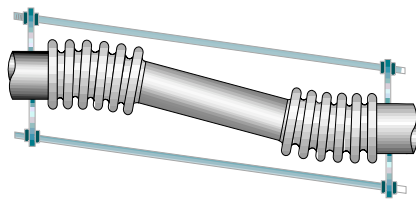

UNIVERSAL TIED (EFUTEJ)

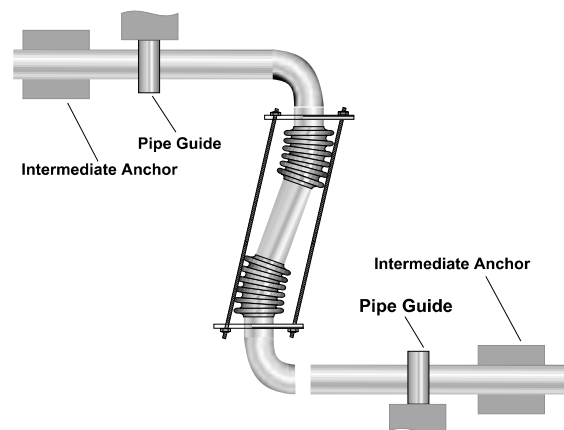

Sometimes a universal expansion joint has a very heavy center spool that can exert excessive weight on the bellows elements. To protect the bellows elements from excessive lateral loads, a support system such as a slotted hinge can be installed across the individual bellows elements to support the dead weight of the center spool.



APPLICATIONS (CONTINUED)

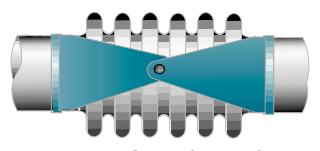

HINGED (EFHJ)

Style EFHJ Hinged Expansion Joints have a single bellows with overall length restrained by hinge hardware designed to accommodate pressure thrust. A hinged expansion joint allows angular movement in a single plane.

Style EFUHJ Universal Hinged Expansion Joints have two bellows separated by a pipe spool with overall length restrained by hinge hardware designed to contain pressure thrust. A hinged universal expansion joint accepts *large lateral* movements in a single plane with very low spring forces.

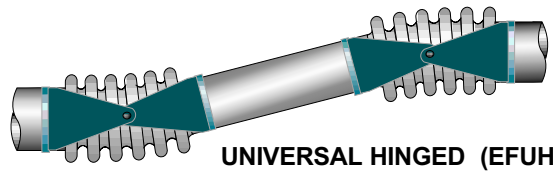

UNIVERSAL HINGED (EFUHJ)

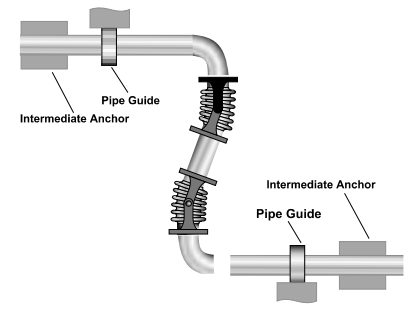

A three-hinge system can accommodate very large movements with very low reaction loads on the adjacent equipment. This is a very attractive application for large diameter hot piping systems if the movements are in the same plane.

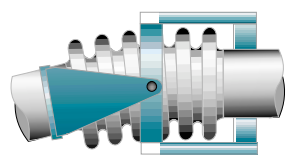

GIMBAL (EFGJ)

Style EFGJ Gimbal Expansion Joints have a single bellows and gimbal hardware designed to resist pressure thrust. The gimbal expansion joint hardware operates like the universal joint on a drive shaft to accommodate angular movements in any plane.

Style EFUGJ Universal Gimbaled Expansion Joints are similar to the hinged universals except that the two expansion joints are gimbal type. The advantage of this arrangement is the ability of the expansion joint to accept large lateral movements and independent angular movements in any plane.

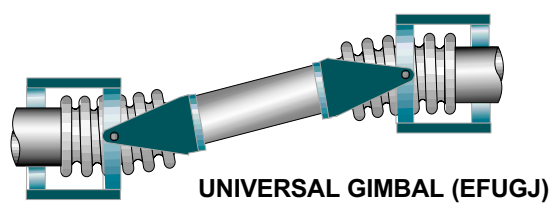

UNIVERSAL GIMBAL (EFUGJ)

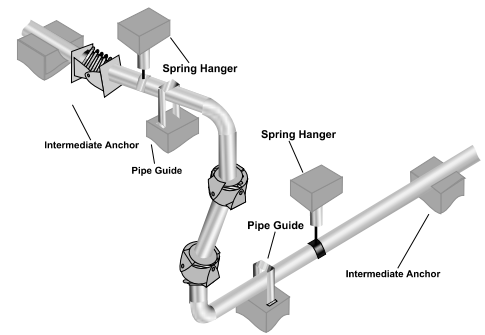

A system consisting of two gimbals and a hinge can accommodate very large movements with very low reaction loads on the adjacent equipment. This is a very attractive application for large diameter hot piping systems even if the movements are complex and not in a single plane.



Pressure Balanced Expansion Joints are devices which produce no pressure thrust forces in the piping system on the main anchors. In addition to eliminating the pressure thrust, the expansion joint can accept axial compression, axial extension, lateral and angular movements. The balancing thrust is created by using a balancing bellows.

Pressure Balanced Elbows are expansion joints which can consist of a single or double bellows in the flow section, and a balancing bellows of equal area on the back side of the elbow. Tie rods attach the outboard end of the balancing bellows to the outboard end of the flow bellows. Under pressure the tie rods are loaded with the pressure thrust force. If the flow bellows compresses in service, the balancing bellows extends the same amount without exposing the adjacent anchors to pressure thrust forces. However, the spring forces associated with bellows movements are imposed on the adjacent equipment. A pressure balanced elbow type expansion joint can accept axial compression, axial extension, lateral movements and very limited angular motion.

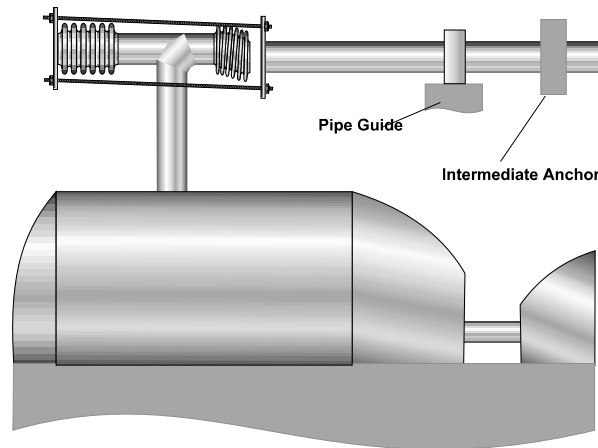

In-Line Pressure Balanced Expansion Joints consist of single or double (universal) bellows to accept the piping induced axial compression, extension and lateral movements. An oversize bellows with approximately two times the area of the flow bellows is used to create an annular pressure chamber that produces a balancing pressure thrust force. Tie rods are used to link the bellows elements and contain the pressure thrust force. In-Line pressure balanced expansion joints are typically used in straight pipe runs between intermediate anchors (non pressure thrust resistant) or adjacent to rotating equipment that cannot operate with large externally applied loads.

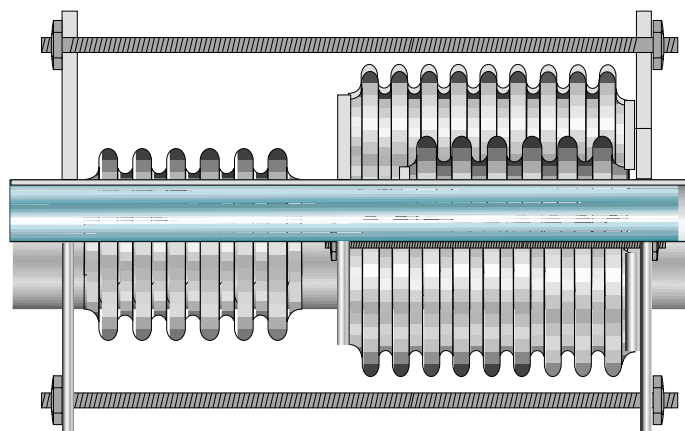

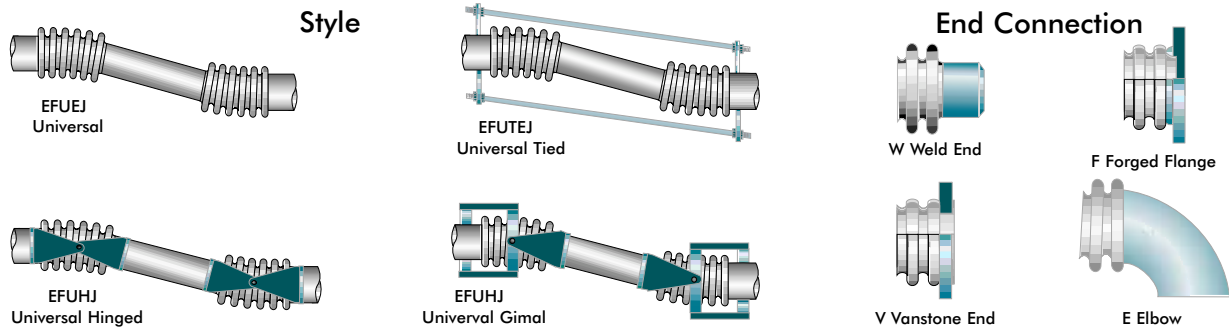

PN10 - 12"

Model No. <small>Nominal Bore x Overall Length</small>	Design Temperature upto	Maximum Working Pressure	Lateral Movement (inch)	Axial Movement (inch)	Cycle Life (Cycles)	End Flanges Details
2" x 12"	250°C	10Kg/cm ²	±0.39	±0.39	12000	BS10 Table D
2½" x 12"	250°C	10Kg/cm ²	±0.39	±0.39	12000	BS10 Table D
3" x 12"	250°C	10Kg/cm ²	±0.39	±0.39	12000	BS10 Table D
4" x 12"	250°C	10Kg/cm ²	±0.31	±0.39	12000	BS10 Table D
5" x 12"	250°C	10Kg/cm ²	±0.31	±0.39	12000	BS10 Table D
6" x 12"	250°C	10Kg/cm ²	±0.31	±0.39	12000	BS10 Table D
8" x 12"	250°C	10Kg/cm ²	±0.20	±0.39	12000	BS10 Table D
10" x 12"	250°C	10Kg/cm ²	±0.20	±0.39	12000	BS10 Table D
12" x 12"	250°C	10Kg/cm ²	±0.20	±0.39	12000	BS10 Table D
14" x 12"	250°C	10Kg/cm ²	±0.12	±0.39	12000	BS10 Table D
18" x 12"	250°C	10Kg/cm ²	±0.12	±0.39	12000	BS10 Table D
20" x 12"	250°C	10Kg/cm ²	±0.12	±0.39	12000	BS10 Table D
22" x 12"	250°C	10Kg/cm ²	±0.12	±0.39	12000	BS10 Table D
24" x 12"	250°C	10Kg/cm ²	±0.12	±0.39	12000	BS10 Table D

PN10 - 18"

Model No. <small>Nominal Bore x Overall Length</small>	Design Temperature upto	Maximum Working Pressure	Lateral Movement (inch)	Axial Movement (inch)	Cycle Life (Cycles)	End Flanges Details
2" x 18"	250°C	10Kg/cm ²	±0.79	±0.39	12000	BS10 Table D
2½" x 18"	250°C	10Kg/cm ²	±0.79	±0.39	12000	BS10 Table D
3" x 18"	250°C	10Kg/cm ²	±0.79	±0.39	12000	BS10 Table D
4" x 18"	250°C	10Kg/cm ²	±0.59	±0.39	12000	BS10 Table D
5" x 18"	250°C	10Kg/cm ²	±0.59	±0.39	12000	BS10 Table D
6" x 18"	250°C	10Kg/cm ²	±0.59	±0.39	12000	BS10 Table D
8" x 18"	250°C	10Kg/cm ²	±0.39	±0.39	12000	BS10 Table D
10" x 18"	250°C	10Kg/cm ²	±0.39	±0.39	12000	BS10 Table D
12" x 18"	250°C	10Kg/cm ²	±0.39	±0.39	12000	BS10 Table D
14" x 18"	250°C	10Kg/cm ²	±0.31	±0.39	12000	BS10 Table D
18" x 18"	250°C	10Kg/cm ²	±0.31	±0.39	12000	BS10 Table D
20" x 18"	250°C	10Kg/cm ²	±0.31	±0.39	12000	BS10 Table D
22" x 18"	250°C	10Kg/cm ²	±0.31	±0.39	12000	BS10 Table D
24" x 18"	250°C	10Kg/cm ²	±0.31	±0.39	12000	BS10 Table D

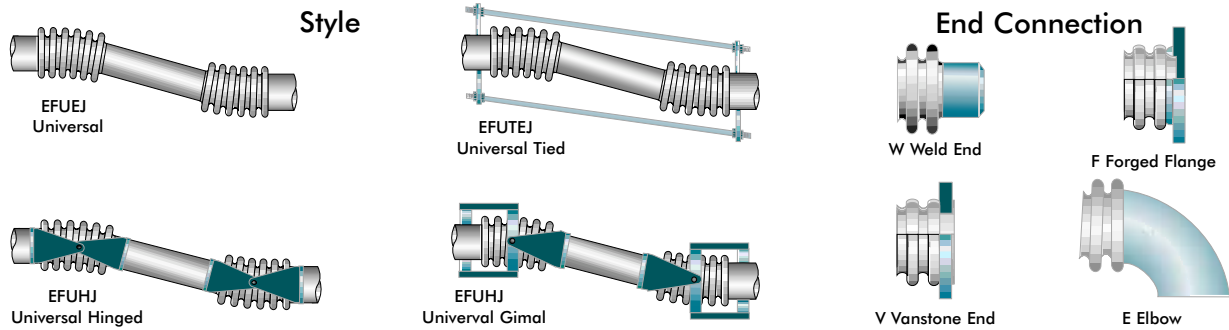

PN10 - 24"

Model No. <small>Nominal Bore x Overall Length</small>	Design Temperature upto	Maximum Working Pressure	Lateral Movement (inch)	Axial Movement (inch)	Cycle Life (Cycles)	End Flanges Details
2" x 24"	250°C	10Kg/cm ²	±1.18	±0.39	12000	Bs10 Table D
2½" x 24"	250°C	10Kg/cm ²	±1.18	±0.39	12000	BS10 Table D
3" x 24"	250°C	10Kg/cm ²	±1.18	±0.39	12000	BS10 Table D
4" x 24"	250°C	10Kg/cm ²	±0.98	±0.39	12000	BS10 Table D
5" x 24"	250°C	10Kg/cm ²	±0.98	±0.39	12000	BS10 Table D
6" x 24"	250°C	10Kg/cm ²	±0.98	±0.39	12000	BS10 Table D
8" x 24"	250°C	10Kg/cm ²	±0.59	±0.39	12000	BS10 Table D
10" x 24"	250°C	10Kg/cm ²	±0.59	±0.39	12000	BS10 Table D
12" x 24"	250°C	10Kg/cm ²	±0.59	±0.39	12000	BS10 Table D
14" x 24"	250°C	10Kg/cm ²	±0.47	±0.39	12000	BS10 Table D
18" x 24"	250°C	10Kg/cm ²	±0.47	±0.39	12000	BS10 Table D
20" x 24"	250°C	10Kg/cm ²	±0.47	±0.39	12000	BS10 Table D
22" x 24"	250°C	10Kg/cm ²	±0.47	±0.39	12000	BS10 Table D
24" x 24"	250°C	10Kg/cm ²	±0.47	±0.39	12000	BS10 Table D

PN10 - 36"

Model No. <small>Nominal Bore x Overall Length</small>	Design Temperature upto	Maximum Working Pressure	Lateral Movement (inch)	Axial Movement (inch)	Cycle Life (Cycles)	End Flanges Details
2" x 36"	250°C	10Kg/cm ²	±1.97	±0.39	12000	Bs10 Table D
2½" x 36"	250°C	10Kg/cm ²	±1.97	±0.39	12000	BS10 Table D
3" x 36"	250°C	10Kg/cm ²	±1.97	±0.39	12000	BS10 Table D
4" x 36"	250°C	10Kg/cm ²	±1.57	±0.39	12000	BS10 Table D
5" x 36"	250°C	10Kg/cm ²	±1.57	±0.39	12000	BS10 Table D
6" x 36"	250°C	10Kg/cm ²	±1.57	±0.39	12000	BS10 Table D
8" x 36"	250°C	10Kg/cm ²	±0.98	±0.39	12000	BS10 Table D
10" x 36"	250°C	10Kg/cm ²	±0.98	±0.39	12000	BS10 Table D
12" x 36"	250°C	10Kg/cm ²	±0.98	±0.39	12000	BS10 Table D
14" x 36"	250°C	10Kg/cm ²	±0.78	±0.39	12000	BS10 Table D
18" x 36"	250°C	10Kg/cm ²	±0.79	±0.39	12000	BS10 Table D
20" x 36"	250°C	10Kg/cm ²	±0.79	±0.39	12000	BS10 Table D
22" x 36"	250°C	10Kg/cm ²	±0.79	±0.39	12000	BS10 Table D
24" x 36"	250°C	10Kg/cm ²	±0.79	±0.39	12000	BS10 Table D

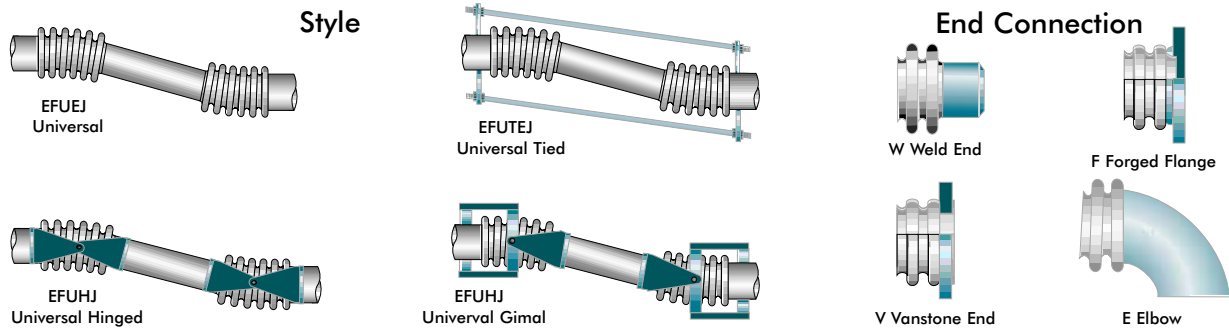

PN16 - 12"

Model No. <small>Nominal Bore x Overall Length</small>	Design Temperature upto	Maximum Working Pressure	Lateral Movement (inch)	Axial Movement (inch)	Cycle Life (Cycles)	End Flanges Details
2" x 12"	250°C	16Kg/cm ²	±0.39	±0.39	12000	ANSI B16.5 # 150
2½" x 12"	250°C	16Kg/cm ²	±0.39	±0.39	12000	ANSI B16.5 # 150
3" x 12"	250°C	16Kg/cm ²	±0.39	±0.39	12000	ANSI B16.5 # 150
4" x 12"	250°C	16Kg/cm ²	±0.31	±0.39	12000	ANSI B16.5 # 150
5" x 12"	250°C	16Kg/cm ²	±0.31	±0.39	12000	ANSI B16.5 # 150
6" x 12"	250°C	16Kg/cm ²	±0.31	±0.39	12000	ANSI B16.5 # 150
8" x 12"	250°C	16Kg/cm ²	±0.16	±0.39	12000	ANSI B16.5 # 150
10" x 12"	250°C	16Kg/cm ²	±0.16	±0.39	12000	ANSI B16.5 # 150
12" x 12"	250°C	16Kg/cm ²	±0.16	±0.39	12000	ANSI B16.5 # 150
14" x 12"	250°C	16Kg/cm ²	±0.12	±0.39	12000	ANSI B16.5 # 150
18" x 12"	250°C	16Kg/cm ²	±0.12	±0.39	12000	ANSI B16.5 # 150
20" x 12"	250°C	16Kg/cm ²	±0.12	±0.39	12000	ANSI B16.5 # 150
22" x 12"	250°C	16Kg/cm ²	±0.12	±0.39	12000	ANSI B16.5 # 150
24" x 12"	250°C	16Kg/cm ²	±0.12	±0.39	12000	ANSI B16.5 # 150

PN16 - 18"

Model No. <small>Nominal Bore x Overall Length</small>	Design Temperature upto	Maximum Working Pressure	Lateral Movement (inch)	Axial Movement (inch)	Cycle Life (Cycles)	End Flanges Details
2" x 18"	250°C	16Kg/cm ²	±0.79	±0.39	12000	ANSI B16.5 # 150
2½" x 18"	250°C	16Kg/cm ²	±0.79	±0.39	12000	ANSI B16.5 # 150
3" x 18"	250°C	16Kg/cm ²	±0.79	±0.39	12000	ANSI B16.5 # 150
4" x 18"	250°C	16Kg/cm ²	±0.59	±0.39	12000	ANSI B16.5 # 150
5" x 18"	250°C	16Kg/cm ²	±0.59	±0.39	12000	ANSI B16.5 # 150
6" x 18"	250°C	16Kg/cm ²	±0.59	±0.39	12000	ANSI B16.5 # 150
8" x 18"	250°C	16Kg/cm ²	±0.28	±0.39	12000	ANSI B16.5 # 150
10" x 18"	250°C	16Kg/cm ²	±0.28	±0.39	12000	ANSI B16.5 # 150
12" x 18"	250°C	16Kg/cm ²	±0.28	±0.39	12000	ANSI B16.5 # 150
14" x 18"	250°C	16Kg/cm ²	±0.24	±0.39	12000	ANSI B16.5 # 150
18" x 18"	250°C	16Kg/cm ²	±0.24	±0.39	12000	ANSI B16.5 # 150
20" x 18"	250°C	16Kg/cm ²	±0.24	±0.39	12000	ANSI B16.5 # 150
22" x 18"	250°C	16Kg/cm ²	±0.24	±0.39	12000	ANSI B16.5 # 150
24" x 18"	250°C	16Kg/cm ²	±0.24	±0.39	12000	ANSI B16.5 # 150

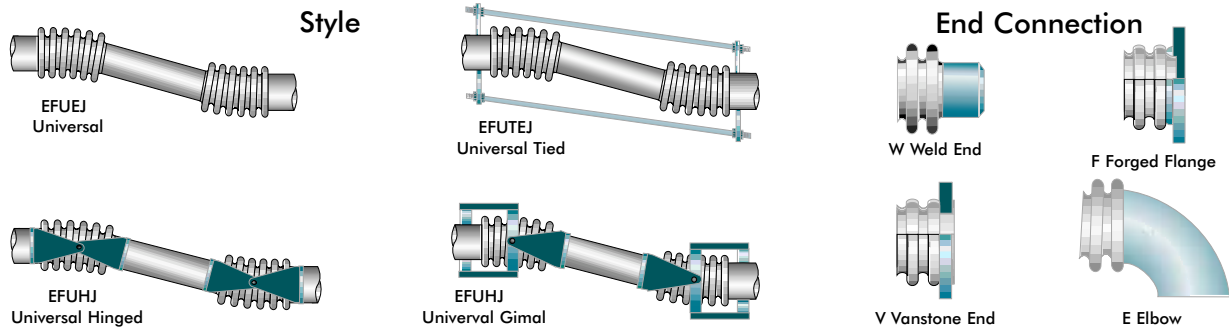

PN16 - 24"

Model No. <small>Nominal Bore x Overall Length</small>	Design Temperature upto	Maximum Working Pressure	Lateral Movement (inch)	Axial Movement (inch)	Cycle Life (Cycles)	End Flanges Details
2" x 24"	250°C	16Kg/cm ²	±1.18	±0.39	12000	ANSI B16.5 # 150
2½" x 24"	250°C	16Kg/cm ²	±1.18	±0.39	12000	ANSI B16.5 # 150
3" x 24"	250°C	16Kg/cm ²	±1.18	±0.39	12000	ANSI B16.5 # 150
4" x 24"	250°C	16Kg/cm ²	±0.98	±0.39	12000	ANSI B16.5 # 150
5" x 24"	250°C	16Kg/cm ²	±0.98	±0.39	12000	ANSI B16.5 # 150
6" x 24"	250°C	16Kg/cm ²	±0.98	±0.39	12000	ANSI B16.5 # 150
8" x 24"	250°C	16Kg/cm ²	±0.47	±0.39	12000	ANSI B16.5 # 150
10" x 24"	250°C	16Kg/cm ²	±0.47	±0.39	12000	ANSI B16.5 # 150
12" x 24"	250°C	16Kg/cm ²	±0.47	±0.39	12000	ANSI B16.5 # 150
14" x 24"	250°C	16Kg/cm ²	±0.39	±0.39	12000	ANSI B16.5 # 150
18" x 24"	250°C	16Kg/cm ²	±0.39	±0.39	12000	ANSI B16.5 # 150
20" x 24"	250°C	16Kg/cm ²	±0.39	±0.39	12000	ANSI B16.5 # 150
22" x 24"	250°C	16Kg/cm ²	±0.39	±0.39	12000	ANSI B16.5 # 150
24" x 24"	250°C	16Kg/cm ²	±0.39	±0.39	12000	ANSI B16.5 # 150

PN16 - 36"

Model No. <small>Nominal Bore x Overall Length</small>	Design Temperature upto	Maximum Working Pressure	Lateral Movement (inch)	Axial Movement (inch)	Cycle Life (Cycles)	End Flanges Details
2" x 36"	250°C	16Kg/cm ²	±1.97	±0.39	12000	ANSI B16.5 # 150
2½" x 36"	250°C	16Kg/cm ²	±1.97	±0.39	12000	ANSI B16.5 # 150
3" x 36"	250°C	16Kg/cm ²	±1.97	±0.39	12000	ANSI B16.5 # 150
4" x 36"	250°C	16Kg/cm ²	±1.57	±0.39	12000	ANSI B16.5 # 150
5" x 36"	250°C	16Kg/cm ²	±1.57	±0.39	12000	ANSI B16.5 # 150
6" x 36"	250°C	16Kg/cm ²	±1.57	±0.39	12000	ANSI B16.5 # 150
8" x 36"	250°C	16Kg/cm ²	±0.79	±0.39	12000	ANSI B16.5 # 150
10" x 36"	250°C	16Kg/cm ²	±0.79	±0.39	12000	ANSI B16.5 # 150
12" x 36"	250°C	16Kg/cm ²	±0.79	±0.39	12000	ANSI B16.5 # 150
14" x 36"	250°C	16Kg/cm ²	±0.63	±0.39	12000	ANSI B16.5 # 150
18" x 36"	250°C	16Kg/cm ²	±0.63	±0.39	12000	ANSI B16.5 # 150
20" x 36"	250°C	16Kg/cm ²	±0.63	±0.39	12000	ANSI B16.5 # 150
22" x 36"	250°C	16Kg/cm ²	±0.63	±0.39	12000	ANSI B16.5 # 150
24" x 36"	250°C	16Kg/cm ²	±0.63	±0.39	12000	ANSI B16.5 # 150